



(ENGINEERS)

**SUBMITTAL DATA**

**MODEL C-SR-WTS (single blade)**

**Ceiling Radiation Damper for wood truss systems**

U.L.555C CLASSIFIED ASSEMBLIES AND ULC S112.2 LISTED

Approved for 1 Hour Wood Truss Floor/Ceiling Assemblies

**Application and Design**

The Model C-SR-WTS is a rectangular UL Classified ceiling (radiation) damper, single blade style, approved for steel duct, flex duct and ductless installations in approved UL ceiling/floor designs as listed below\*\*. These dampers provide protection up to 9" x 18" openings.

**Standard Construction**

**Frame:** Galvanized Steel (gauge as required by UL)

**Blades:** Galvanized Steel, uninsulated 80 sq. in. and under, sizes over 80 sq. in. insulated with 1/8" kaowool flex wrap non-quilted insulation (gauge as required by UL)

**Springs:** Corrosion resistant steel spring

**Fusible Link:** Replaceable 165°F (75°C) std. (212° F optional)

Designed and tested in accordance to standards: UL 555C, ULC S112.2. Labeled and listed by UL/ULC under File# R25411. They meet all the NFPA-90A, IBC Code, and other major code requirements for Ceiling (Radiation) Dampers.

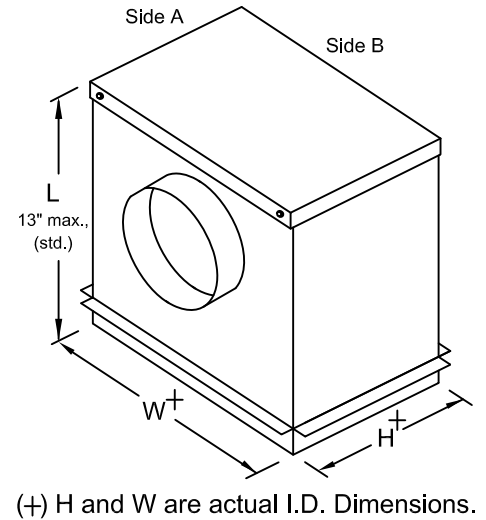
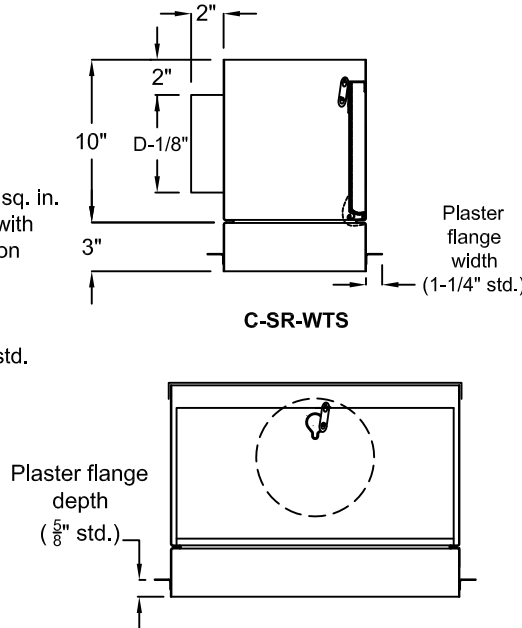

**Note:**

Due to continuing research, UE reserves the right to change specifications without notice.

Standard Sizes (duct)		
Min. Size (W x H)	Max. Size (W x H)	*Inlet size (D)
6" x 4" [152mm x 102mm]	9" x 18" 229mm x 457mm	4"Ø (102mm) min. 12"Ø (305mm) oval equivalent (max.)

\*Duct connections may be provided as oval equivalent.

\*\*Intended for installation in Fire Resistance Design Nos. L546, L558, L574, L585, M520, P533, P538, P545, P547, & P559 as detailed in the UL Fire Resistance Directory and are similar to fire resistance rated ceiling constructions represented in the International Building Code. Contact factory regarding design nos. not listed above.

**SUGGESTED SPECIFICATION**

Wood Truss Ceiling damper's shall be Model C-S/R-WTS by United Energetech. Ceiling dampers shall bear the Underwriters' Laboratories label and be rated for both steel duct and flex duct installations. No external damper supports shall be required for ceiling dampers up to and including 162 sq. inches in area. Ceiling dampers shall be non-asbestos type and be furnished with a fusible link. Volume controller furnished where shown.

**Manufacturer's Recommendations**

All moving parts of the damper must be inspected and cycled once the first year and at intervals not greater than every 4 years or in accordance with the latest edition of NFPA 90A, 92A, and local codes. In addition, fuse links shall be removed and inspected for corrosion. Dry lubricants are recommended.

**Options:**

- Boot Rail
- Inlet Connection
  - Round/Oval Equivalent  Square/Rectangular
  - Side:  A  B
- Alternate Plaster Flange
  - 1-1/4" deep x 1-1/4" wide
  - 2" deep x 1-1/4" wide  3" deep x 1-1/4" wide
- Alternate 212° F (100°C) fusible link

UL approved with steel and aluminum diffuser

Job Name:	<input type="checkbox"/> <b>MODEL C-SR-WTS (Single Blade)</b>	DRAWN BY:		DATE:	REV. DATE:
Location:		CLJ	4-6-14	7-28-16	
Architect:		REV. NO.	APPROVED BY:	DWG. NO.:	
Engineer:	5	BGT	<b>P-93b</b>		
Contractor:					